

HFM SERIES

DC Inverter DX Air Handling Unit

Heat Recovery and Purification Type

MAKE AIR TREATMENT MORE HEALTHY AND ENERGY SAVING

HOLTOP

Beijing Holtop Air Conditioning Co., Ltd.

Factory address : No. 5 Yard, 7th Guanggu Street, Badaling Economic Development Zone, Yanqing District, Beijing, China

International marketing center

Room 2101, Headquarter Center No. 25, Tian An Hi-Tech Ecological Park, No. 555 Panyu Ave, Guangzhou, China

Tel: 86-20-39388201-8023

Skype: susanwoo08

Website: www.holtop.com

E-mail: info@holtop.com



* Data is subject to changes without notification due to product improvement



Everyone needs to breathe
25,000 times
 per day

- Clean and fresh air is essential
- HOLTOP keeps working on providing you with integrated fresh, clean, comfortable and intelligent air solutions.
- HOLTOP delivers fresh and clean air, just for your healthy breathing!

Contents

About HOLTOP	03
Product Overview	05
Features of indoor unit	07
Features of outdoor unit	11
Intelligent control system	19
Specification	23
Combination ways of indoor unit	28
Cooling capacity correction coefficient table	34
Project reference	35

ABOUT HOLTOP

2002
 HOLTPO WAS FOUND

200000+
 Units Production Capacity

70000+
 m² area

100+
 countries exportation

30+
 sales organizations



ISO Certifications



Dozens of National Patents Owner



Industrial Standards Participated



World Leading Manufacturer



Zhongguancun&National High-tech Enterprise



Equipment Supplier for Beijing Olympics and the Shanghai World Expo



DC Inverter DX Air Handling Unit

Heat Recovery and Purification Type

HOLTOP HFM series DX Air Handling Unit includes DC Inverter DX air conditioner outdoor unit and constant frequency DX air conditioner outdoor unit these two series. The capacity of DC inverter DX AHU is 10-20P, while the capacity of constant frequency DX AHU is 5-18P. On the basis of constant frequency DX AHU, the newly developed DC Inverter DX AHU adopts the enhanced vapor injection technology to open a new era of low-temperature heating. The new design of air-conditioning system and self-developed control program give full play to product performance and bring users a more comfortable air-conditioning experience.



Combined Type Heat Recovery Indoor Unit

Air-cooled Outdoor Unit



Item/Series		DC Inverter Series	constant Frequency Series
Cooling capacity (kw)		25 - 509	12 - 420
Heating Capacity (kw)		28 - 569	18 - 480
Airflow (m ³ /h)		5500 - 95000	2500 - 80000
Frequency Range of Compressor (Hz)		20 - 120	/
Max. length of Pipe (m)		70	50
Max. Drop (m)		25	25
Operating Range	Cooling	Outdoor DB temperature (°C)	-5 - 52
		Indoor WB temperature (°C)	15 - 24
	Heating	Indoor DB temperature (°C)	15 - 27
		Outdoor WB temperature (°C)	-20 - 27

Features of Indoor Unit



Core heat recovery technologies

Holtop heat recovery technology can effectively reduce the heat and cold load caused by ventilation, it's energy saving and environmental protection.



Breath healthy air

Say no to indoor and outdoor dust, particles, formaldehyde, peculiar smell and other harmful substances, enjoy the natural fresh and health air.



Comfortable ventilation

Our goal is to bring you the comfortable and clean air.



CROSSFLOW TOTAL HEAT EXCHANGER

Holtop crossflow total heat exchanger was made of imported ER paper, the thin corrugated paper produced with special technology will make sure the higher heat transmissibility, fire resistance(grade up to B2) stronger tire resistance and mold prevent(grade up to level 0).

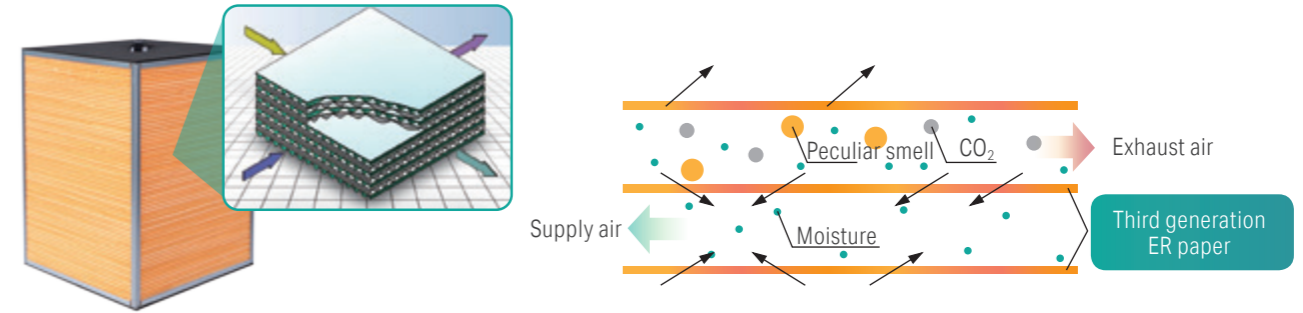

CROSS FLOW PLATE HEAT EXCHANGER

Holtop cross flow plate heat exchanger was made of aluminum foils with 0.12mm thickness. In order to avoid the two airflows come cross without touch, Holtop have been committed to the research of cross-flow plate heat exchangers for many years. Multiple special processes are adopted to ensure the air tightness and improve the heat exchange performance, so that the heat exchange efficiency is highly improved.

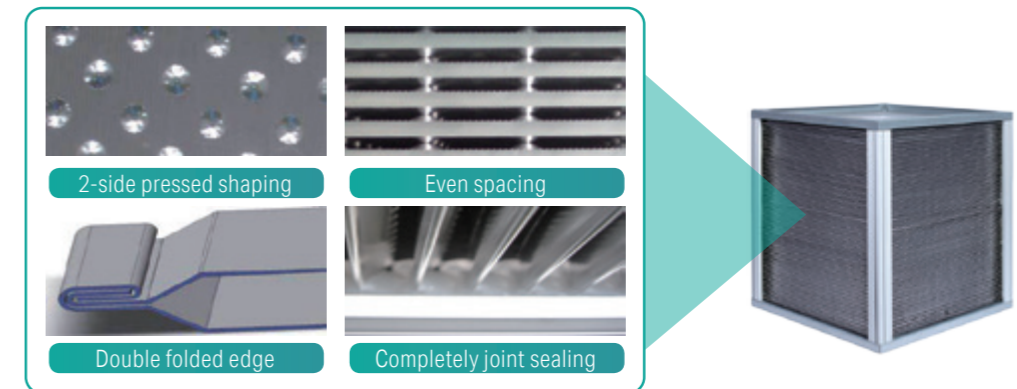

ROTARY HEAT EXCHANGER

The surface of the wheel is coated with a 3A molecular sieve coating, which has the functions of heat storage and moisture adsorption (total heat), and exchanges energy with the fresh air and exhaust air passing through, to realize the energy recovery and saving.

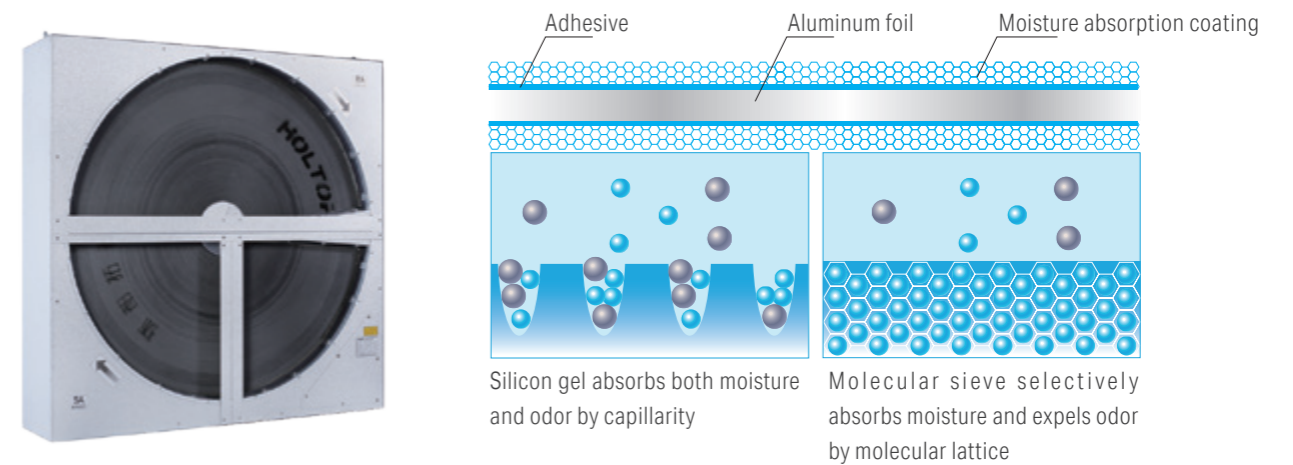

PM2.5 SOLUTION

High Efficiency To Remove The Haze

Equipped with a high-efficiency filtration filters, it can effectively remove PM2.5 particles carried by the air and ensure clean indoor air quality.



*Take MCCO28WP as an example, and the efficiency is obtained from the test of BEET-33139A "Air Purification Device PM2.5 Purification Performance Testing Method".

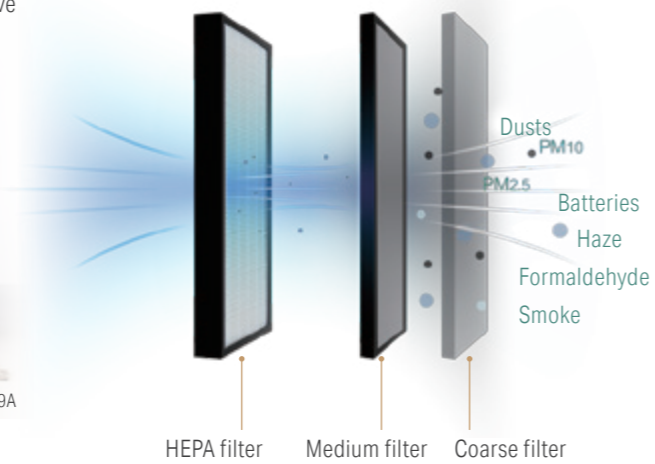

Bring Forest Fresh Air To Your Buildings

The high-efficiency filtration filters can effectively intercept harmful components in the air, such as dust, pollen, smog, car exhaust, etc. It can filter more than 95% of PM2.5 particles after being tested by the authoritative organization to ensure clean indoor air.

- High efficiency**
Filtered particles ≥ 2.5 microns in the air with an efficiency as high as 95%.
- Longer service life**
The newly developed filter can be cleaned many times and has a service life of more than one year.
- Low air resistance**
Using high-efficiency, environmentally friendly filter materials, stable performance, low air resistance.
- Easy installation**
The size of the filter is the same as the air outlet of the unit. The frame is fixed to the unit, which is extremely convenient for installation and disassembly.

Graph of PM2.5 concentration change within 2 hours

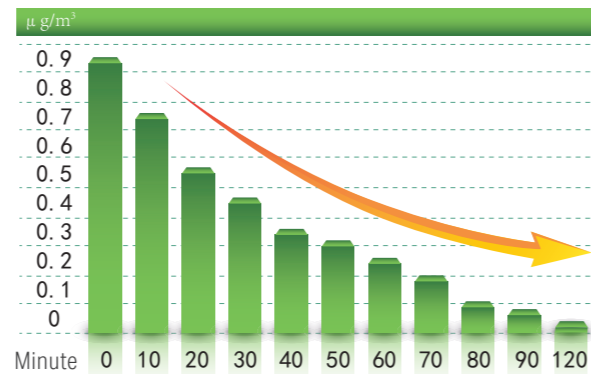

INDOOR FORMALDEHYDE REMOVAL SOLUTION

The indoor unit can optionally be equipped with a formaldehyde removal module, which can effectively filter and decompose formaldehyde molecules; coupled with fresh air replacement and dilution, double removal of formaldehyde.

- Efficient adsorption**
The activated carbon filter can efficiently adsorb formaldehyde and other harmful substances, and the purification degree can reach 90%.
- Powerful disintegration**
The cold catalyst filter quickly decomposes formaldehyde into water and carbon dioxide through the catalyst.
- Easy installation**
The formaldehyde removal module is easy to install and can be replaced by side-drawing, which is simple and convenient.

BRING OUTDOOR FRESH AIR

With this AHU, the outdoor fresh air will be brought into the room, and the indoor air quality will be highly improved by increasing oxygen concentration, decreasing carbon dioxide and remove the peculiar smell and other harmful gas.



ANTI-COLD WIND DESIGN

When the heating is turned on, the heat exchanger fins of the indoor unit will start to supply air after preheating; during the defrosting, the indoor unit will shut down according to the judgement of smart program.

SENSITIVE TEMPERATURE SENSOR

The temperature sensor with high stability and sensitivity can accurately detect the subtle temperature changes. The unit can adjust the temperature in time and accurately, make sure a more comfortable experience.

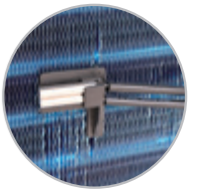

PATENTED CABINET STRUCTURE

- High-density polyurethane foam is sandwiched in the double-layer panel, and the thermal transmittance is T2.
- Unique cold-bridge free structure, the thermal-bridging factor is class TB2.
- Proprietary frame structure, the strength is up to class D1 (the top standard in the Europe).



VARIOUS FILTRATION CLASS

By selecting the plate type, bag type, chemical type, electronic purification type and other filters, it can meet the requirements of different filtration level ranging from G3-H13. At the same time, It provides the fresh air and a comfortable breathing environment by filtering, absorbing and decomposing the harmful substances.



Features of Outdoor Unit

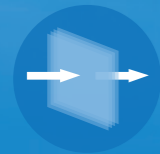

High Heat Exchange Efficiency

Multiple leading technologies, building a stronger, more stable and efficient cooling system



Silence operation

Innovative noise canceling techniques, minimizing the operation noise for both indoor and outdoor unit, creating a silent environment



Compact design

New casing design with better stability and appearance. The inner system elements is from world famous brands to ensure high quality.



DC INVERTER DESIGN TO SAVE ENERGY

The compressor as well as the fan motor of the outdoor unit has been upgraded to DC inverter type, responding rapidly to the indoor unit working conditions to meet variable heating and cooling demand.

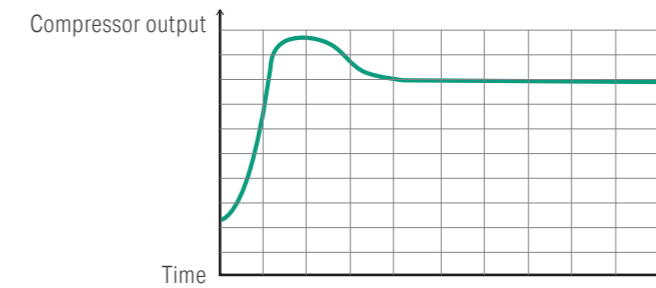

ENHANCED VAPOR INJECTION (EVI) TECHNOLOGY

The compressor is using the EVI technology, which is featured by high reliability, wide application envelope and easy manifolding. It can greatly improve the heating capacity under extremely low ambient temperature.

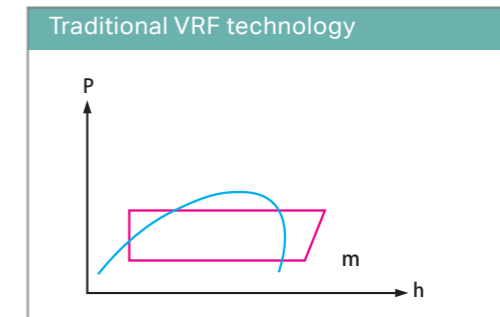
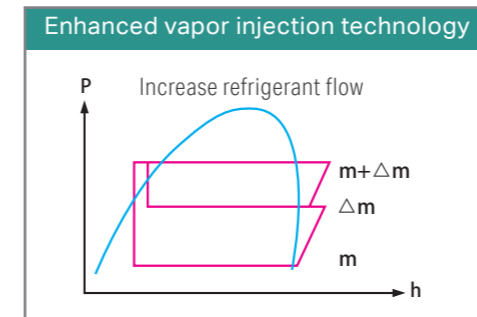

TWO-GRADES DEEP SUBCOOLING TECHNOLOGY

The outdoor unit is using improved heat exchanger, lowering the subcooling level, and matching with high efficiency plate heat exchange achieving deep two-grades subcooling, which can reach 28°C. And at the same time, increase the piping length to ensure the unit's efficiency.

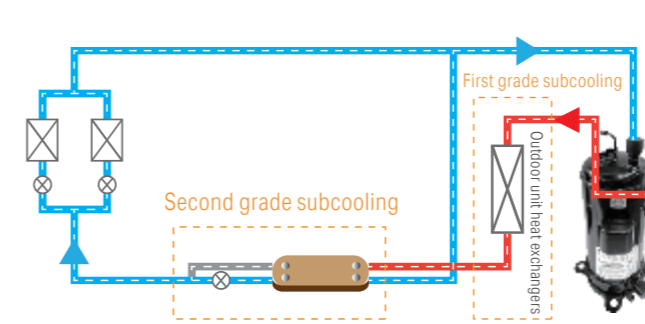

Two-grades subcooling working principle

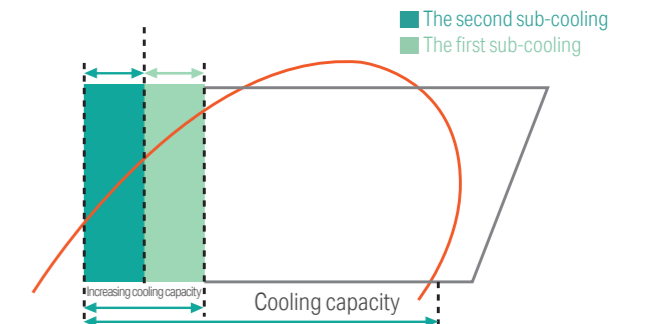

System pressure-enthalpy diagram



Normal copper pipe heat exchanger is larger in size, so the heat loss is larger and the heat exchange efficiency is lower.



Stainless steel plate heat exchanger is smaller in size and with groove design, so the heat loss is little and the heat exchange efficiency is higher.

HIGH EFFICIENT OIL SEPARATOR

The separator is using centrifugal rotary design, forcing the high pressure air to form a high speed rotary air stream. Under the influence of centrifugal force and gravity, the lubricating oil will be separated and running down on the cylinder wall, and later back to the compressor.

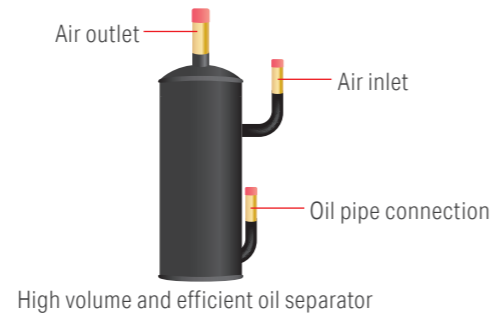

MULTIPLE SENSORS FOR RELIABLE HEATING

There are 12 temperature sensors and 2 pressure sensors to detect the real-time status. With these data and our self-developed control program, the compressor and all other parts will be adjusted accordingly, ensuring running stability and efficiency.

BETTER ANTI-FROSTING DESIGN

New heat exchanging flow design ensuring high heat exchange efficiency. Bottom anti-frosting design making defrosting and heating more efficient.

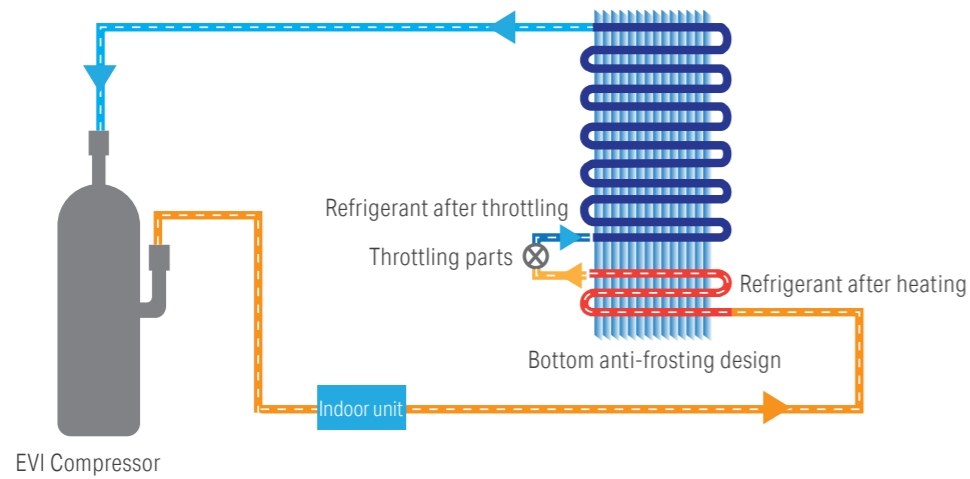

STABLE AND EFFICIENT INNOVATIVE THROTTLING DESIGN

The big outdoor unit is using two Electronic Expansion Valves under parallel control, greatly improved its precision and system stability.

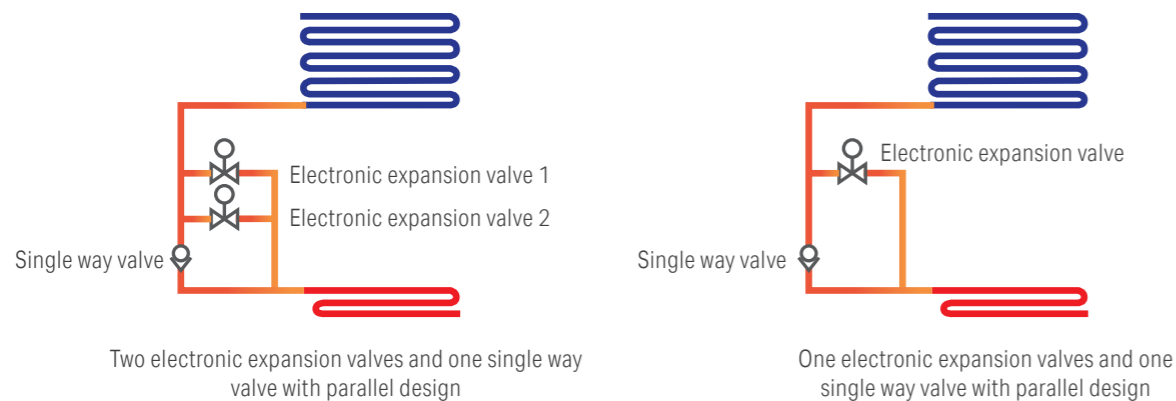

UPGRADED FOUR-WAY VALVE

The new four-way valve has better design to improve its pressure relief capability, so to avoid liquid hammering. Under same conditions, its capability is 25% higher than other brands. The slider is now built with PPS material, which allowing the valve to work under -25~120°C, and max 130°C. (Other brands is using PA and PTFE material, which can stand -25~100°C, and max 120°C.)

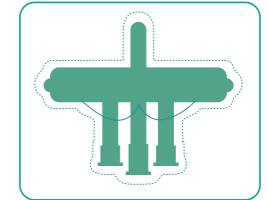

RELIABLE OPERATION AND FLEXIBLE APPLICATION

Wide range of operating conditions, satisfying cooling and heating under extreme ambient temperature

The DC inverter outdoor unit is still capable of cooling under -5°C. Under -20°C, it's still capable of heating.

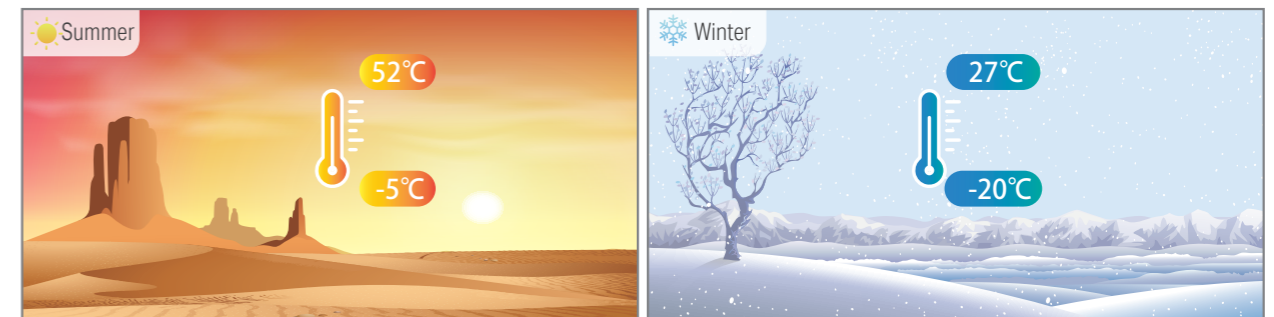

ENVIRONMENTAL-FRIENDLY REFRIGERANT

Better performance

HOLTOP DX AHU is using R410A refrigerant, which do not include any tritium, so its ODP equals to 0. It can lower the CO2 emission, so to avoid damaging the ozone layer.

Moreover, R410A is not flammable, has great thermal stability and volumetric refrigeration capacity, making the unit more energy saving and environmental-friendly.

Refrigerant Type	R22	R407C	R410A
Volumetric cooling capacity	1.0	0.9	1.4
ODP	0.05	0	0



NEWLY DEVELOPED U-SHAPED HEAT EXCHANGER

Based on many years of outdoor unit development and manufacturing experience and user feedback, Holtop has developed a new generation of U-shaped heat exchanger with three-sided heat exchange. The heat exchanger is the core component of the refrigeration system, and its performance directly determines the reliability and energy efficiency of the air conditioning system.

- The U-shaped heat exchanger with three-sided heat exchange can effectively use the airflow of the fan, maximize the heat exchange area and greatly improve the heat exchange efficiency without increasing the size of the unit.
- Compact structure, high strength, more convenient for installation and maintenance.
- The hydrophilic aluminum fin is used to improve the heat transfer coefficient of the heat exchange wet film and the overall heat transfer coefficient of the unit.

Three-sided heat exchange U-shaped heat exchanger structure

- Adopting $\phi 7.94$ high-tooth high-threaded copper tube with moderate flow rate, it can achieve the best comprehensive performance of heat exchange and defrosting.

The distance between $\phi 7$ copper pipes is small, frost is easy to form, and the frost layer is thicker, which affects the defrosting time and heat exchange efficiency.

The diameter of the $\phi 9.52$ copper pipes is large, the disturbance to the heat transfer boundary layer is small, and the heat transfer efficiency is low.

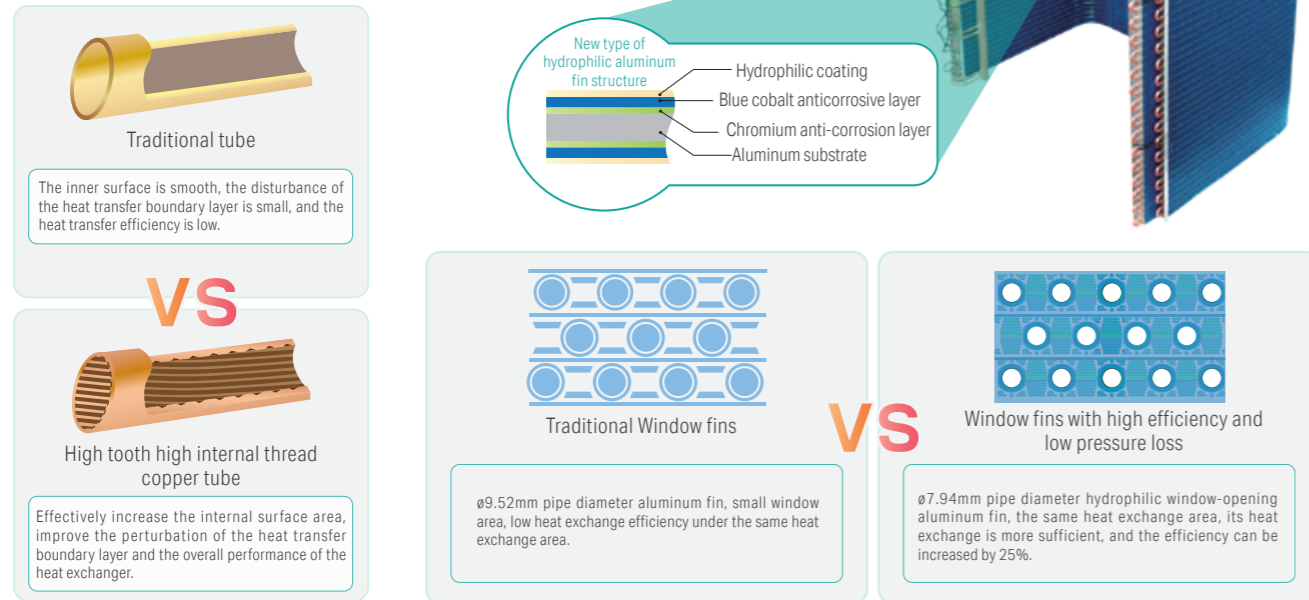

HIGH-EFFICIENCY REFRIGERANT HEAT EXCHANGE FLOW PATH

The high-efficiency 2in1 refrigerant confluence technology reduces the space occupied by the liquid-phase refrigerant on the heat transfer pipeline, and at the same time increases the degree of subcooling, making the long connecting pipe more efficient.

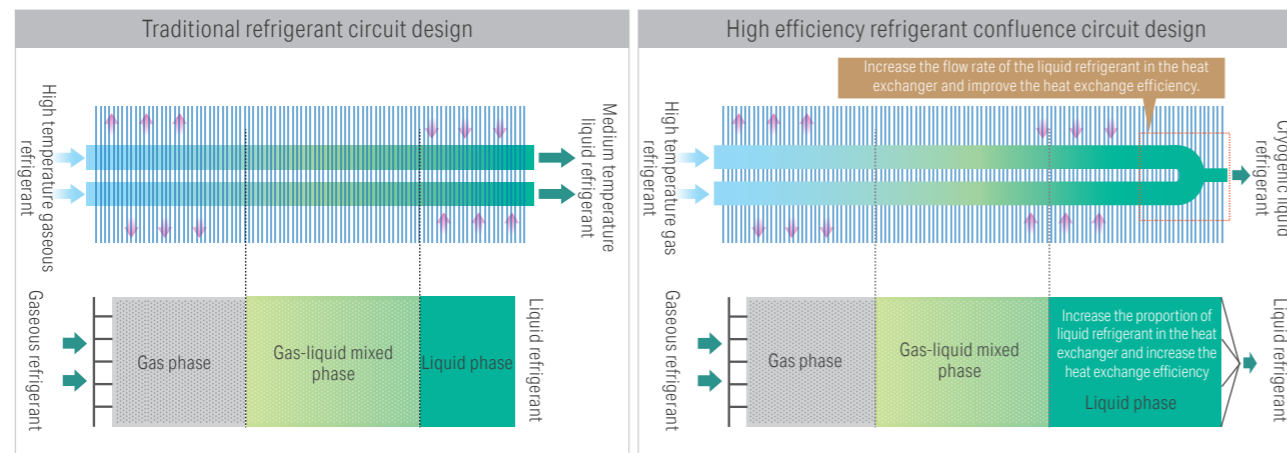

STREAMLINED FAN

The cooling fan of the top discharge outdoor unit adopts 750mm large-diameter axial fan, and the contact between the airflow and the blades is smoother, reducing the noise caused by eddy currents, increasing the air volume and significantly reducing the operating noise.



The side air outlet outdoor units HFM050 and 060 adopt 460mm axial fan blades, and HFM080 adopts 470mm axial fan blades.

MODULE ASSEMBLY

Through outdoor unit alternate operation technology, the operation time of each outdoor unit is balanced, the safety and reliability of the system are improved, and the service life of the unit is prolonged.



LONG PIPING DESIGN

The equivalent length of the piping connection between the DC inverter outdoor unit and the indoor unit is 70m, and the maximum drop can reach 25m. The on-site installation and layout of indoor and outdoor units are more flexible.

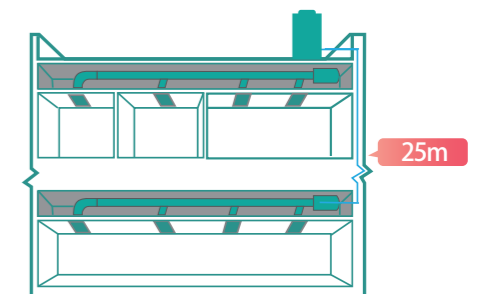

HUMANIZED FREE COMBINATION OF OUTDOOR UNIT

- The outdoor unit is modular design, when multiple units are arranged in a neat and consistent area, can effectively save space.
- The outdoor unit has a complete range of specifications, which can be adjusted to match various cooling requirements through the combination of modules.
- The unit can reasonably select a combination of modules according to the limitations of transportation and installation space to meet on-site installation requirements.

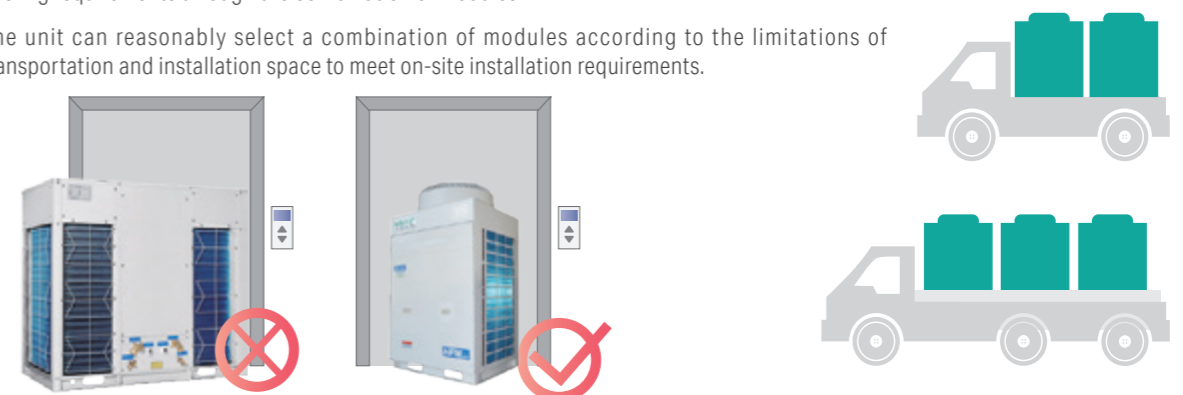

STRUCTURAL FEATURES OF THE TOP DISCHARGE OUTDOOR UNIT

9 Low-noise technologies

1 Low-speed high-efficiency motor

2 Hermetic scroll compressor

3 Special rubber shock pad for ompressor

4 New vortex axial fan blade

5 Large size outlet grille

6 Low noise wind deflector design

7 Analysis of outlet air flow simulation

8 Optimized design of pipe shock absorption, fixed in proper position to avoid vibration noise

9 Reducing refrigerant flow rate noise

STRUCTURAL FEATURES OF SIDE DISCHARGE OUTDOOR UNIT

8 Standard processes

1 The side plate adopts the grille to protect the condenser fins, and the heat exchange is sufficient.

2 The top plate and bottom plate are shaped at one time.

3 Large arc corners with soft lines.

4 Streamlined fan blades with large air volume with better heat dissipation performance.

5 The door panel is disassembled separately, easy to maintain.

6 The door panel adopts transverse ribs to make it more stable.

7 The mesh cover is made of PP material has good weather resistance and structural strength.

8 Reserved holes are provided on the front, back and sides, and the direction of connecting cables and piping is more flexible.

Humanized Design



Intelligent control

Plentiful, practical and user-friendly control functions, making operation easier and more reliable.



Flexible combination

Beyond imagination, simplified design, let our DX air handling unit more convenient and flexible.



CUSTOMIZED MODE SELECTION FUNCTION

Multiple running mode can be selected according to customer's requirements. Both cooling and heating mode have 3 options: air-conditioning function, fresh air function, and comfortable air function, improving user experience and making users more comfortable.



SELF-DEVELOPED CONTROLLER

The self-developed HFM series controller has advanced control logic. It has the intelligent functions including system protection, safety, comfort, alarm, etc., to make the system running more reliable and safety.



DC inverter controller Standard controller

RS485 COMMUNICATION

MODBUS RTU communication protocol is available with strong compatibility, making the connection more convenient

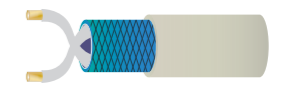

AUTOMATIC JUDGMENT OF REFRIGERANT CHARGE

The system is equipped with high precision sensor to judge automatically the charge conditions of refrigerant, and monitor the running status in real time.

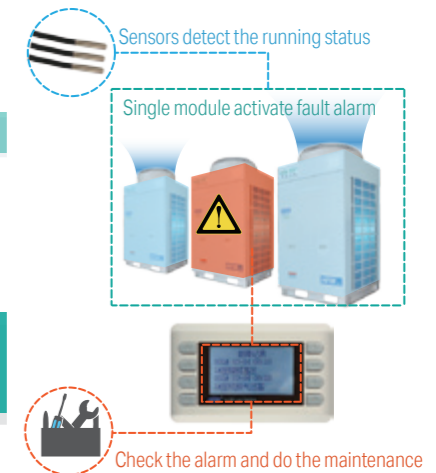

FULL REDUNDANCY WITH EASY PARTS MANAGEMENT

A central controller allows you to decide the quantity of modules active at any time. If a module requires maintenance, other modules in the system will continue to operate, ensuring minimal capacity loss.

INTELLIGENT FAULT ALARM FOR BOTH INDOOR UNIT AND OUTDOOR UNIT

The controller for indoor unit and outdoor unit can display fault information in text, which is convenient for users and service personnel to know about the fault information and make fast maintenance.

EFFICIENT DEFROSTING

With the self-developed high efficiency, low pressure heat exchanger and low-noise large-impeller fan, it can improve the heat exchange efficiency of outdoor unit, which can postpone the frosting process, and reduce defrosting time effectively. The defrosting logic will judge the device defrosting condition according to multiple aspects, like fin temperature, environmental temperature and running time, etc., precisely get the right timing to enter or exit defrosting process, reduce defrosting frequency and time, to ensure the indoor comfort.

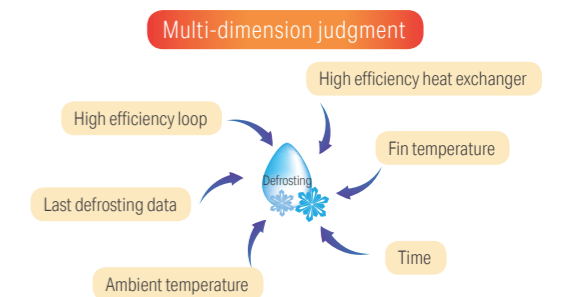
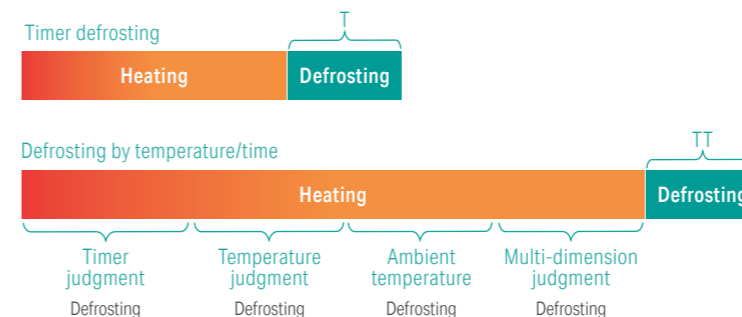

PROPOSAL 1. COMFORT CONTROL SYSTEM

Dedicated controller, combines the convenience of independent controller and the functions of group control in centralized controller, can control multiple outdoor units in the same time, it is flexible and widely used in medium or small office-level business space.

Functions and Explanation

- Heat pump type: cooling/heating/supply air/ Constant temperature and humidity
- LCD control panel can display setting temperature, working mode, system Real-Time Clock(optional), week(optional), ON/OFF status and fault display, etc.
- Timer ON/OFF
- Power to restart(optional)
- Auxiliary electric heating



PROPOSAL 2. FUNCTIONAL CONTROL SYSTEM

Building management systems based on the MODBUS protocol, can be directly connected to the centralized control system through the standard MODBUS communication interface of the unit, it can achieve centralized intelligent monitoring without access to conversion equipment, which is suitable for large and medium-sized air-conditioning places.

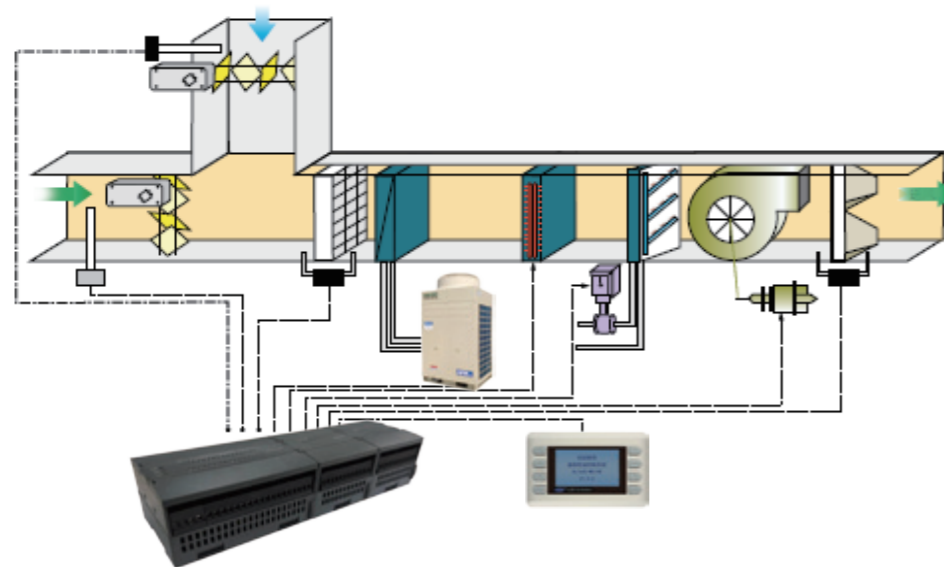

PLC CONTROLLER

The functions and explanation for PLC controller

The PLC controller with 485 communication function can make the PLC control system enter the same layer of network to communicate with other PLCs and share data information through its communication module. It can also enter a distributed system to form substations, complete substation monitoring tasks, and communicate with the central control station or building management system at the same time. Each PLC controller can handle more data points through the I/O extension card, and can connect up to 32pcs indoor units and 320pcs outdoor units to meet the air conditioning needs of most projects. At the same time, it can be connected to the building management system through MODBUS communication.

- Display the current running, stopping or fault status of the fans and units.
- Monitoring the resistance of primary, medium and high efficiency filters. When the resistance value exceeds the standard, it prompts to replace or clean the filter.
- Remotely monitor the operation of each unit (such as remote on/off of the unit, fault alarm, etc.).
- Monitor the temperature and humidity of supply air, return air, and each air-conditioning room, and the system can give the value and status for each monitoring point.
- When the unit is turned off, the fresh air valve will close immediately while the fan will stop after a while. The return air will dry the coil and equipment with air to ensure dryness.
- Monitor the working condition of the fire damper and connect it with the fire signal. If a fire alarm occurs, the valves of the unit can be closed, the supply fan and exhaust fan will stop, and the exhaust fan will start.
- The opening of supply air, return air and supply air valve will be controlled according to the enthalpy value of supply air, return air and indoor temperature and humidity requirements, so as to reduce energy consumption as much as possible while ensuring indoor air quality.
- When the unit is running, the corresponding signal can be output through the PID program calculation in the controller to achieve the purpose of adjusting the start and stop of the compressor, controlling the opening of the steam valve, humidifier, etc., so as to keep the temperature of the air-conditioning area within the required range.
- All parameter information can be automatically stored through the computer. The operation plan of the unit can be optimized by analyzing the operation fault alarm information of the unit to realize intelligent and low-power operation.

TOPOLOGY DIAGRAM FOR CONTROL NETWORK

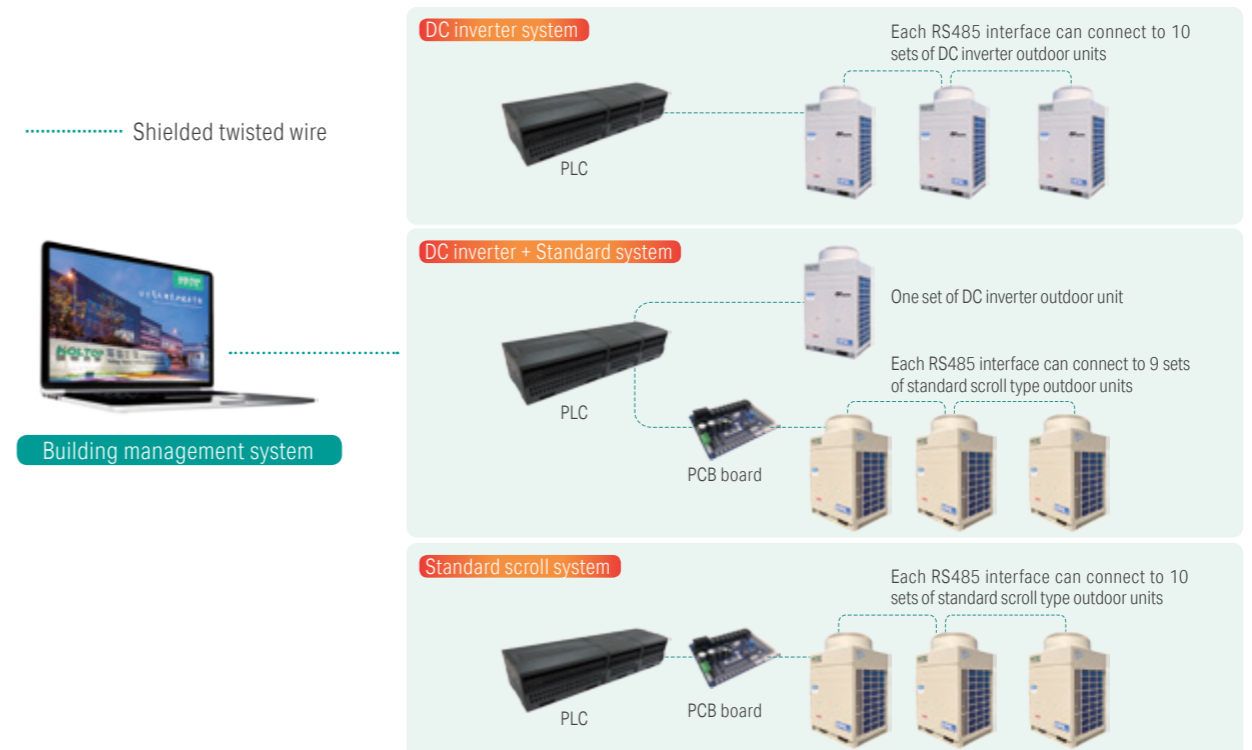

SPECIFICATIONS OF DC INVERTER DX AIR HANDLING UNIT

Specifications	Indoor unit	HZN-10	HZN-12	HZN-15	HZN-18	HZN-20	
	Outdoor unit	HFM-10HA1-DC	HFM-12HA1-DC	HFM-15HA1-DC	HFM-18HA1-DC	HFM-20HA1-DC	
Nominal cooling capacity	kW	25.5	28.3	33.8	40.4	50.9	
Nominal heating capacity	kW	28.3	31.8	37.9	45.4	56.9	
Power supply	/	380V/3PH/50Hz					
Indoor unit	Dimensions	/ Subject to specific functional module					
	Airflow	m³/h	5500	6500	8000	11000	12000
	External pressure	Pa	150	250	350	350	350
	Fan type	/	High efficient DC fan				
	Fan power	kW	1.5	2.2	3	4	4
Outdoor unit	Compressor type	/	DC inverter compressor				
	Cooling power	kW	6.34	7.36	10.21	11.61	15.82
	Heating power	kW	6.83	7.81	10.42	12.93	17.14
	L*W*H	mm	990×850×1810	990×850×1810	990×850×1810	1345×850×1810	1345×850×1810
	N.W	kg	210	216	225	270	280
Refrigerant	Type	R410A					
	Charging volume (kg)	8.3	8.4	8.5	9.2	12	
Connecting pipe	Connection mode	Welding					
	Liquid pipe diameter (mm)	ø15.88					
	Air pipe diameter (mm)	ø25.4			ø28.58		
	Drainage pipe	DN32					

Specifications	Indoor unit	HZN-24	HZN-30	HZN-36	HZN-40		
	Outdoor unit	HFM-12HA1-DC×2	HFM-15HA1-DC×2	HFM-18HA1-DC×2	HFM-20HA1-DC×2		
Nominal cooling capacity	kW	56.6	67.6	80.8	101.8		
Nominal heating capacity	kW	63.6	75.8	90.8	113.8		
Power supply	/	380V/3PH/50Hz					
Indoor unit	Dimensions	/ Subject to specific functional module					
	Airflow	m³/h	12000	15000	18000	21000	
	External pressure	Pa	350	450	450	450	
	Fan type	/	High efficient DC fan				
	Fan power	kW	5.5	7.5	7.5	11	
Outdoor unit	Compressor type	/	DC inverter compressor				
	Cooling power	kW	7.36×2	10.21×2	11.61×2	15.82×2	
	Heating power	kW	7.81×2	10.42×2	12.93×2	17.14×2	
	L*W*H	mm	990×850×1810	990×850×1810	1345×850×1810	1345×850×1810	
	N.W	kg	216×2	225×2	270×2	280×2	
Refrigerant	Type	R410A					
	Charging volume (kg)	8.4×2	8.5×2	9.2×2	12×2		
Connecting pipe	Connection mode	Welding					
	Liquid pipe diameter (mm)	ø15.88*2					
	Air pipe diameter (mm)	ø25.4*2			ø28.58*2		
	Drainage pipe	DN32					

- Note:**
1. Nominal cooling capacity is tested under the conditions of indoor dry/wet bulb temperature 27°C/19°C and outdoor dry/web bulb temperature 35°C/24°C;
 2. Nominal heating capacity is tested under the conditions of indoor dry/wet bulb temperature 20°C/15°C and outdoor dry/web bulb temperature 7°C/6°C;
 3. All indoor and outdoor units are not charged with refrigerant out of factory;
 4. The above charging volume of refrigerant is based on the length of the indoor and outdoor connecting pipes of 8 meters. The charging volume is only for reference, please adjust it according to the actual situation on site.

SPECIFICATIONS OF DC INVERTER DX AIR HANDLING UNIT

Specifications	Indoor unit	HZN-54	HZN-60	HZN-72	HZN-80		
	Outdoor unit	HFM-18HA1-DC×3	HFM-20HA1-DC×3	HFM-18HA1-DC×4	HFM-20HA1-DC×4		
Nominal cooling capacity	kW	121.2	152.7	161.6	203.6		
Nominal heating capacity	kW	136.2	170.7	181.6	227.6		
Power supply	/	380V/3PH/50Hz					
Indoor unit	Dimensions	/ Subject to specific functional module					
	Airflow	m³/h	24000	30000	35000	45000	
	External pressure	Pa	450	550	550	550	
	Fan type	/	High efficient DC fan				
	Fan power	kW	11	15	15	15	
Outdoor unit	Compressor type	/	DC inverter compressor				
	Cooling power	kW	11.61×3	15.82×3	11.61×4	15.82×4	
	Heating power	kW	12.93×3	17.14×3	12.93×4	17.14×4	
	L*W*H	mm	1345×850×1810	1345×850×1810	1345×850×1810	1345×850×1810	
	N.W	kg	270×3	280×3	270×4	280×4	
Refrigerant	Type	R410A					
	Charging volume (kg)	9.2×3	12×3	9.2×4	12×4		
Connecting pipe	Connection mode	Welding					
	Liquid pipe diameter (mm)	ø15.88*3			ø15.88*4		
	Air pipe diameter (mm)	ø28.58*3			ø28.58*4		
	Drainage pipe	DN32					

Specifications	Indoor unit	HZN-100	HZN-120	HZN-140	HZN-160	HZN-200	
	Outdoor unit	HFM-20HA1-DC×5	HFM-15HM-DC×6	HFM-20HA1-DC×7	HFM-20HA1-DC×8	HFM-20HA1-DC×10	
Nominal cooling capacity	kW	254.5	282.8	356.3	407.2	509	
Nominal heating capacity	kW	284.5	317.8	398.3	455.2	569	
Power supply	/	380V/3PH/50Hz					
Indoor unit	Dimensions	/ Subject to specific functional module					
	Airflow	m³/h	50000	60000	70000	80000	95000
	External pressure	Pa	600	600	750	750	800
	Fan type	/	High efficient DC fan				
	Fan power	kW	22	22	30	37	45
Outdoor unit	Compressor type	/	DC inverter compressor				
	Cooling power	kW	15.82×5	15.82×6	15.82×7	15.82×8	15.82×10
	Heating power	kW	17.14×5	17.14×6	17.14×7	17.14×8	17.14×10
	L*W*H	mm	1345×850×1810	1345×850×1810	1345×850×1810	1345×850×1810	1345×850×1810
	N.W	kg	280×5	280×6	280×7	280×8	280×10
Refrigerant	Type	R410A					
	Charging volume (kg)	12×5	12×6	12×7	12×8	12×10	
Connecting pipe	Connection mode	Welding					
	Liquid pipe diameter (mm)	ø15.88×5	ø15.88×6	ø15.88×7	ø15.88×8	ø15.88×10	
	Air pipe diameter (mm)	ø28.58×5	ø28.58×6	ø28.58×7	ø28.58×8	ø28.58×10	
	Drainage pipe	DN32					

- Note:**
1. Nominal cooling capacity is tested under the conditions of indoor dry/wet bulb temperature 27°C/19°C and outdoor dry/web bulb temperature 35°C/24°C;
 2. Nominal heating capacity is tested under the conditions of indoor dry/wet bulb temperature 20°C/15°C and outdoor dry/web bulb temperature 7°C/6°C;
 3. All indoor and outdoor units are not charged with refrigerant out of factory;
 4. The above charging volume of refrigerant is based on the length of the indoor and outdoor connecting pipes of 8 meters. The charging volume is only for reference, please adjust it according to the actual situation on site.

SPECIFICATIONS OF DX AIR HANDLING UNIT

Specifications	Indoor unit	HZN-5	HZN-6	HZN-8	HZN-10	HZN-12	
	Outdoor unit	HFM-05HA1	HFM-06HA1	HFM-08HA1	HFM-10HA1	HFM-12HA1	
Nominal cooling capacity	kW	12	13.9	19	25.5	30	
Nominal heating capacity	kW	14.9	16.9	21.9	30.7	33.6	
Power supply	/	380V/3PH/50Hz					
Indoor unit	Dimensions	/ Subject to specific functional module					
	Airflow	m³/h	2400	2800	4000	5500	6500
	External pressure	Pa	100	100	100	150	250
	Fan type	/	High-efficient multi blade centrifugal fan				
	Fan power	kW	0.6	0.6	1	1.5	2.2
Outdoor unit	Compressor type	/	Hermetic scroll type				
	Cooling power	kW	4.4	4.9	5.4	7.6	8.8
	Heating power	kW	4.5	4.9	5.5	7.8	8.6
	L*W*H	mm	903×393×1225	903×393×1225	903×393×1357	990×850×1545	990×850×1545
	N.W	kg	110	110	125	190	200
Refrigerant	Type	R410A					
	Charging volume (kg)	3.6	3.7	5	7.8	8	
Connecting pipe	Connection mode	Welding					
	Liquid pipe diameter (mm)	ø9.52	ø9.52	ø9.52	ø15.88	ø15.88	
	Air pipe diameter (mm)	ø15.88	ø15.88	ø22.22	ø28.58	ø28.58	
	Drainage pipe	DN25		DN32			

Specifications	Indoor unit	HZN-15	HZN-18	HZN-20	HZN-24	
	Outdoor unit	HFM-15HA1	HFM-18HA1	HFM-10HA1×2	HFM-12HA1×2	
Nominal cooling capacity	kW	35.4	42	51	60	
Nominal heating capacity	kW	38.3	48.2	61.4	67.2	
Power supply	/	380V/3PH/50Hz				
Indoor unit	Dimensions	/ Subject to specific functional module				
	Airflow	m³/h	8000	8500	11000	12000
	External pressure	Pa	350	350	350	350
	Fan type	/	High-efficient multi blade centrifugal fan			
	Fan power	kW	3	4	4	5.5
Outdoor unit	Compressor type	/	Hermetic scroll type			
	Cooling power	kW	10.4	12.6	7.6×2	8.8×2
	Heating power	kW	10	11.5	7.8×2	8.6×2
	L*W*H	mm	990×850×1810	1345×850×1810	□990×850×1545□×2	□990×850×1545□×2
	N.W	kg	225	260	190×2	200×2
Refrigerant	Type	R410A				
	Charging volume (kg)	10.5	11	7.8×2	8.0×2	
Connecting pipe	Connection mode	Welding				
	Liquid pipe diameter (mm)	ø15.88	ø15.88	ø15.88×2	ø15.88×2	
	Air pipe diameter (mm)	ø28.58	ø28.58	ø28.58×2	ø28.58×2	
	Drainage pipe	DN32				

- Note:**
1. Nominal cooling capacity is tested under the conditions of indoor dry/wet bulb temperature 27°C/19°C and outdoor dry/web bulb temperature 35°C/24°C;
 2. Nominal heating capacity is tested under the conditions of indoor dry/wet bulb temperature 20°C/15°C and outdoor dry/web bulb temperature 7°C/6°C;
 3. All indoor and outdoor units are not charged with refrigerant out of factory;
 4. The above charging volume of refrigerant is based on the length of the indoor and outdoor connecting pipes of 8 meters. The charging volume is only for reference, please adjust it according to the actual situation on site.

SPECIFICATIONS OF DX AIR HANDLING UNIT

Specifications	Indoor unit	HZN-30	HZN-36	HZN-40	
	Outdoor unit	HFM-15HA1×2	HFM-18HA1×2	HFM-10HA1×4	
Nominal cooling capacity	kW	70.8	84	102	
Nominal heating capacity	kW	76.6	96.4	122.8	
Power supply	/	380V/3PH/50Hz			
Indoor unit	Dimensions	/ Subject to specific functional module			
	Airflow	m³/h	15000	18000	21000
	External pressure	Pa	450	450	450
	Fan type	/	High-efficient multi blade centrifugal fan		
	Fan power	kW	7.5	7.5	11
Outdoor unit	Compressor type	/	Hermetic scroll type		
	Cooling power	kW	10.4×2	12.6×2	7.6×4
	Heating power	kW	10.0×2	11.5×2	7.8×4
	L*W*H	mm	(990×850×1810)×2	(1345×850×1810)×2	(990×850×1545)×4
	N.W	kg	225×2	260×2	190×4
Refrigerant	Type	R410A			
	Charging volume (kg)	10.5×2	11.0×2	7.8×4	
Connecting pipe	Connection mode	Welding			
	Liquid pipe diameter (mm)	ø15.88×2	ø15.88×2	ø15.88×4	
	Air pipe diameter (mm)	ø28.58×2	ø28.58×2	ø28.58×4	
	Drainage pipe	DN32			

Specifications	Indoor unit	HZN-48	HZN-60	HZN-72	
	Outdoor unit	HFM-12HA1×4	HFM-15HA1×4	HFM-18HA1×4	
Nominal cooling capacity	kW	120	141.6	168	
Nominal heating capacity	kW	134.4	153.2	192.8	
Power supply	/	380V/3PH/50Hz			
Indoor unit	Dimensions	/ Subject to specific functional module			
	Airflow	m³/h	24000	30000	35000
	External pressure	Pa	450	550	550
	Fan type	/	High-efficient multi blade centrifugal fan		
	Fan power	kW	11	15	15
Outdoor unit	Compressor type	/	Hermetic scroll type		
	Cooling power	kW	8.8×4	10.4×4	12.6×4
	Heating power	kW	8.6×4	10.0×4	11.5×4
	L*W*H	mm	(990×850×1545)×4	(990×850×1810)×4	(1345×850×1810)×4
	N.W	kg	200×4	225×4	260×4
Refrigerant	Type	R410A			
	Charging volume (kg)	8.0×4	10.5×4	11.0×4	
Connecting pipe	Connection mode	Welding			
	Liquid pipe diameter (mm)	ø15.88×4	ø15.88×4	ø15.88×4	
	Air pipe diameter (mm)	ø28.58×4	ø28.58×4	ø28.58×4	
	Drainage pipe	DN32			

- Note:**
1. Nominal cooling capacity is tested under the conditions of indoor dry/wet bulb temperature 27°C/19°C and outdoor dry/web bulb temperature 35°C/24°C;
 2. Nominal heating capacity is tested under the conditions of indoor dry/wet bulb temperature 20°C/15°C and outdoor dry/web bulb temperature 7°C/6°C;
 3. All indoor and outdoor units are not charged with refrigerant out of factory;
 4. The above charging volume of refrigerant is based on the length of the indoor and outdoor connecting pipes of 8 meters. The charging volume is only for reference, please adjust it according to the actual situation on site.

SPECIFICATIONS OF DX AIR HANDLING UNIT

Specifications	Indoor unit	HZN-72	HZN-90	HZN-108	
	Outdoor unit	HFM-12HA1×6	HFM-15HA1×6	HFM-18HA1×6	
Nominal cooling capacity	kW	180	212.4	252	
Nominal heating capacity	kW	201.6	229.8	289.2	
Power supply	/	380V/3PH/50Hz			
Indoor unit	Dimensions	Subject to specific functional module			
	Airflow	m³/h	40000	45000	50000
	External pressure	Pa	550	550	600
	Fan type	/	High-efficient multi blade centrifugal fan		
	Fan power	kW	15	15	22
Outdoor unit	Compressor type	/	Hermetic scroll type		
	Cooling power	kW	8.8×6	10.4×6	12.6×6
	Heating power	kW	8.6×6	10.0×6	11.5×6
	L*W*H	mm	(990×850×1545)×6	(990×850×1810)×6	(1345×850×1810)×6
	N.W	kg	200×6	225×6	260×6
Refrigerant	Type	R410A			
	Charging volume (kg)	8.0×6	10.5×6	11.0×6	
Connecting pipe	Connection mode	Welding			
	Liquid pipe diameter (mm)	ø15.88×6	ø15.88×6	ø15.88×6	
	Air pipe diameter (mm)	ø28.58×6	ø28.58×6	ø28.58×6	
	Drainage pipe	DN40			

Specifications	Indoor unit	HZN-120	HZN-144	HZN-180	
	Outdoor unit	HFM-12HA1×8	HFM-15HA1×8	HFM-18HA1×8	
Nominal cooling capacity	kW	283.2	336	420	
Nominal heating capacity	kW	306.4	385.6	482.2	
Power supply	/	380V/3PH/50Hz			
Indoor unit	Dimensions	Subject to specific functional module			
	Airflow	m³/h	60000	70000	80000
	External pressure	Pa	600	750	750
	Fan type	/	High-efficient multi blade centrifugal fan		
	Fan power	kW	22	30	37
Outdoor unit	Compressor type	/	Hermetic scroll type		
	Cooling power	kW	10.4×8	12.6×8	12.6×8
	Heating power	kW	10.0×8	11.5×8	11.5×10
	L*W*H	mm	(990×850×1810)×8	(1345×850×1810)×8	(1345×850×1810)×10
	N.W	kg	225×8	260×8	260×10
Refrigerant	Type	R410A			
	Charging volume (kg)	10.5×8	11.0×8	11.0×10	
Connecting pipe	Connection mode	Welding			
	Liquid pipe diameter (mm)	ø15.88×8	ø15.88×8	ø15.88×10	
	Air pipe diameter (mm)	ø28.58×8	ø28.58×8	ø28.58×10	
	Drainage pipe	DN50			

- Note:**
1. Nominal cooling capacity is tested under the conditions of indoor dry/wet bulb temperature 27°C/19°C and outdoor dry/web bulb temperature 35°C/24°C;
 2. Nominal heating capacity is tested under the conditions of indoor dry/wet bulb temperature 20°C/15°C and outdoor dry/web bulb temperature 7°C/6°C;
 3. All indoor and outdoor units are not charged with refrigerant out of factory;
 4. The above charging volume of refrigerant is based on the length of the indoor and outdoor connecting pipes of 8 meters. The charging volume is only for reference, please adjust it according to the actual situation on site.

STANDARD COMBINATION INDOOR UNITS

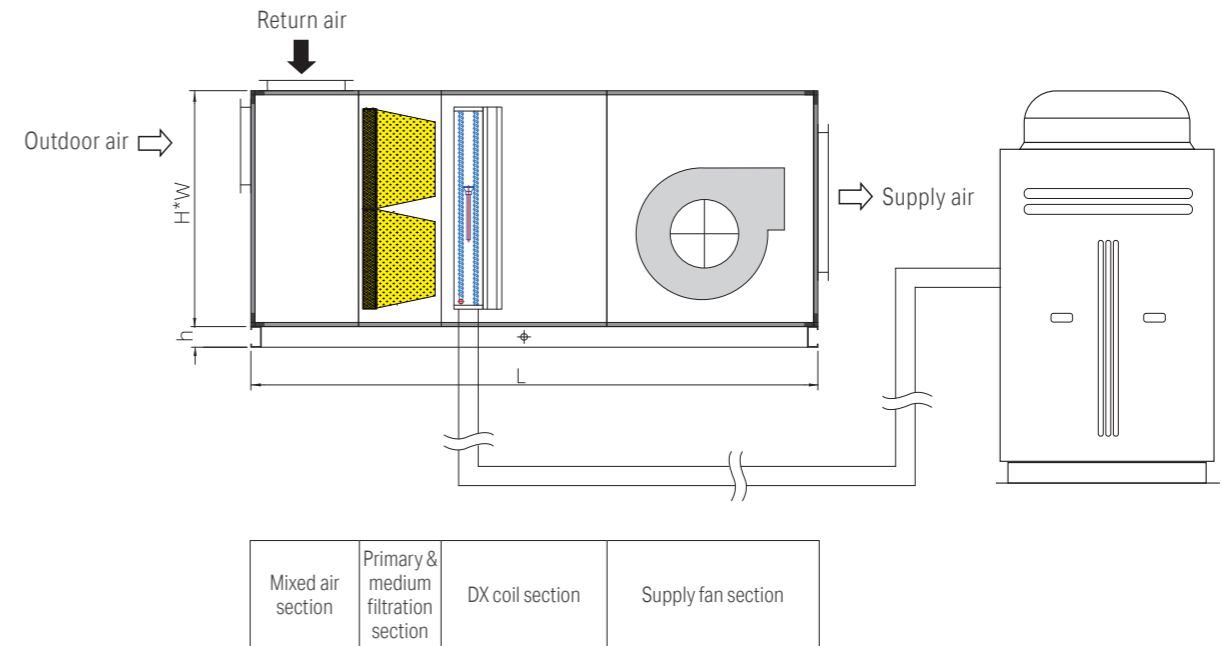

Indoor unit	Machine dimensions (mm)		Duct size (mm)			Weight
	L	H*W	OA	RA	SA	
HZN-5	2480	740*1140	970*175	975*275	315*315	475
HZN-6	2480	740*1140	970*175	975*275	325*325	490
HZN-8	2480	840*1140	970*175	975*275	375*375	515
HZN-10	2580	840*1240	1075*175	1075*275	475*475	545
HZN-12	2580	940*1240	1075*175	1075*275	475*475	564
HZN-15	2680	940*1340	1175*175	1175*375	575*575	575
HZN-18	2680	1040*1340	1175*175	1175*375	575*575	638
HZN-20	2880	1140*1740	1575*175	1575*375	575*575	767
HZN-24	2880	1340*1740	1575*175	1575*375	675*675	818
HZN-30	3080	1440*1840	1675*175	1675*375	775*775	1045
HZN-36	3180	1440*1840	1675*175	1675*375	775*775	1082
HZN-40	3380	1640*2240	2075*175	2075*375	775*775	1681
HZN-48	3580	1740*2240	2075*175	2075*475	875*875	1796
HZN-60	3680	1940*2240	2275*175	2275*475	975*975	1992
HZN-72	3780	2240*2340	2175*175	2175*475	975*975	1958

- Note:**
1. The above dimensions are only for the unit size with 25mm panels, when equipped with 50mm panels, sizes are L+50mm, W+50mm, H+50mm.
 2. H = 100mm.

ENERGY RECOVERY INDOOR UNITS WITH PLATE HEAT EXCHANGERS 1

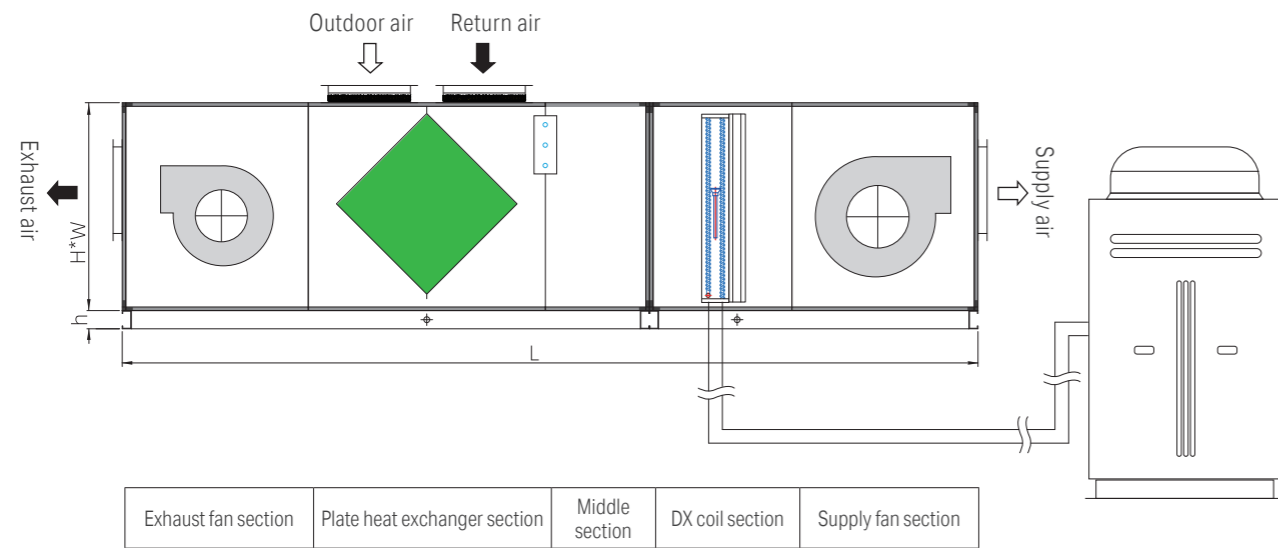

Indoor unit	Machine dimensions (mm)		Duct size (mm)		Weight (kg)
	L	H * W	OA / RA	SA / EA	
HZN-10	3680	840×1240	1075×275	475×475	793
HZN-12	3680	940×1240	1075×275	475×475	821
HZN-15	4080	940×1340	1175×275	575×575	914
HZN-18	4080	1040×1340	1175×375	575×575	1044
HZN-20	4380	1140×1740	1575×475	575×575	1327
HZN-24	4880	1240×1740	1575×475	675×675	1415
HZN-30	4880	1440×1840	1675×575	775×775	1855
HZN-36	5280	1440×1840	1675×575	775×775	2118

Note: 1. The above dimensions are only for the unit size with 25mm panels, when equipped with 50mm panels, sizes are L+50mm, W+50mm, H+50mm.
2. H = 100mm.

ENERGY RECOVERY INDOOR UNITS WITH PLATE HEAT EXCHANGERS 2

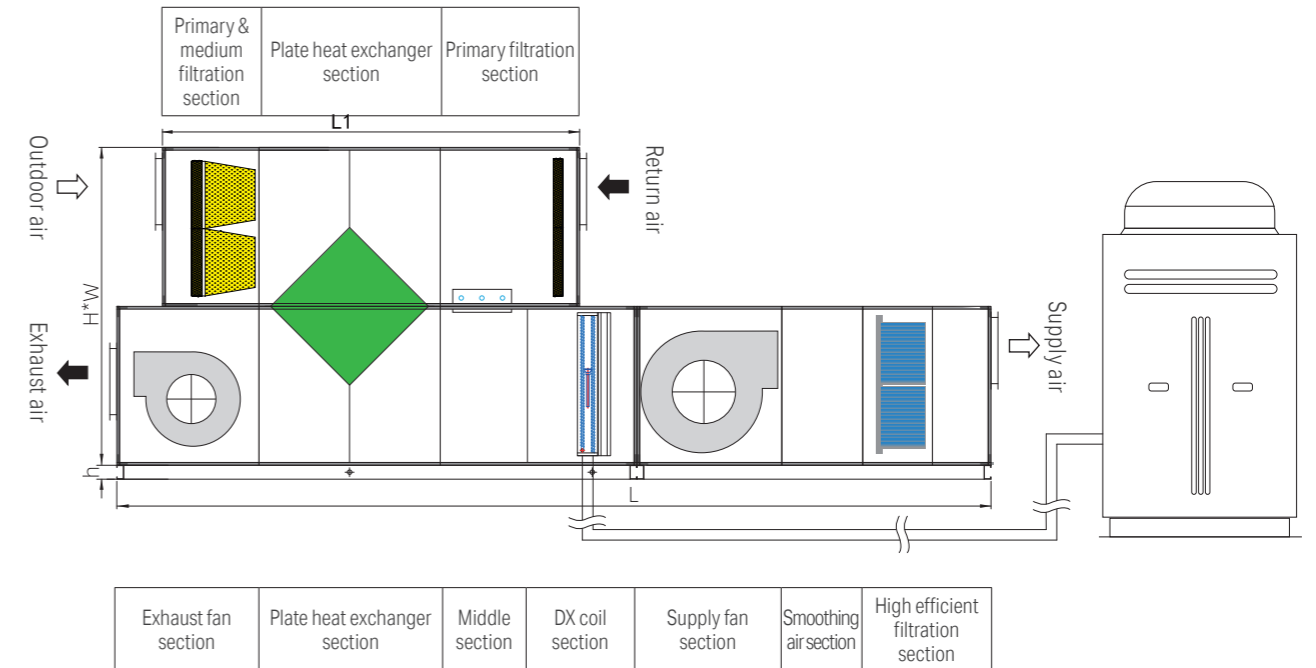

Indoor unit	Machine dimensions (mm)			Duct size (mm)		Weight (kg)
	L	L1	H * W	OA / RA	SA / EA	
HZN-10	5380	2540	1680×1240	1075×275	475×475	1575
HZN-12	5380	2540	1880×1240	1075×375	475×475	1630
HZN-15	5780	2740	1880×1340	1175×375	575×575	1775
HZN-18	5780	2740	2080×1340	1175×375	575×575	2110
HZN-20	6080	2740	2280×1740	1575×475	575×575	2576
HZN-24	6580	2940	2680×1740	1575×475	675×675	2916
HZN-30	6580	3940	2880×1840	1675×475	775×775	3661
HZN-36	6680	3240	2880×1840	1675×575	775×775	4181

Note: 1. The above dimensions are only for the unit size with 25mm panels, when equipped with 50mm panels, sizes are L+50mm, W+50mm, H+50mm.
2. H = 100mm.

ENERGY RECOVERY INDOOR UNITS WITH PLATE HEAT EXCHANGERS 3

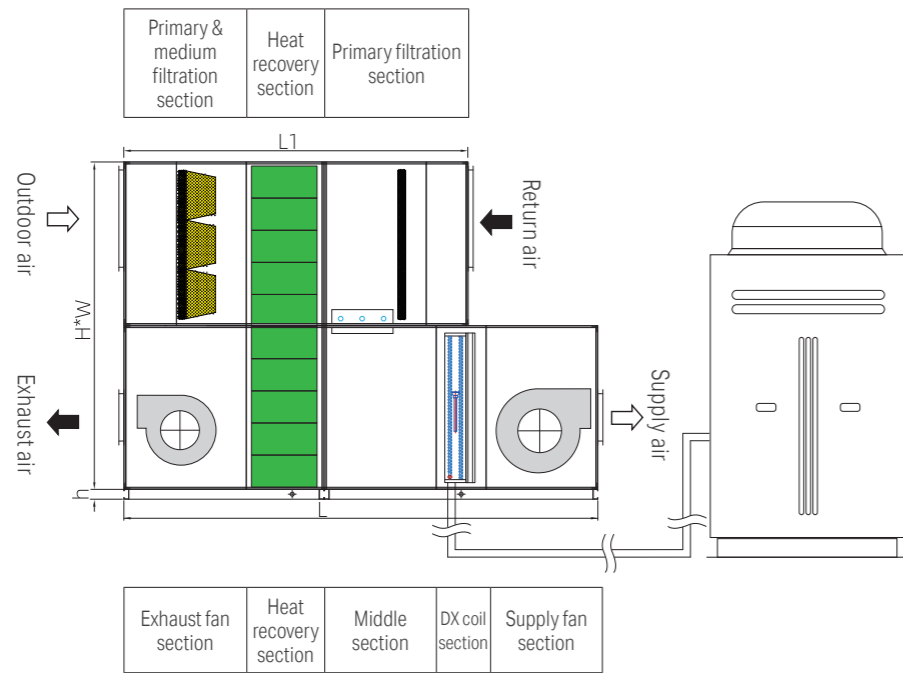

Indoor unit	Machine dimensions (mm)			Duct size (mm)		Weight (kg)
	L	L1	H * W	OA / RA	SA / EA	
HZN-40	5080	3480	3280×2240	1975×575	775×775	2753
HZN-48	5480	3780	3480×2240	2075×675	875×875	2954
HZN-60	6280	4380	3880×2440	2375×675	975×975	3504

Note: 1. The above dimensions are only for the unit size with 25mm panels, when equipped with 50mm panels, sizes are L+50mm, W+50mm, H+50mm.
2. H = 100mm.

ENERGY RECOVERY INDOOR UNITS WITH HEAT RECOVERY WHEEL

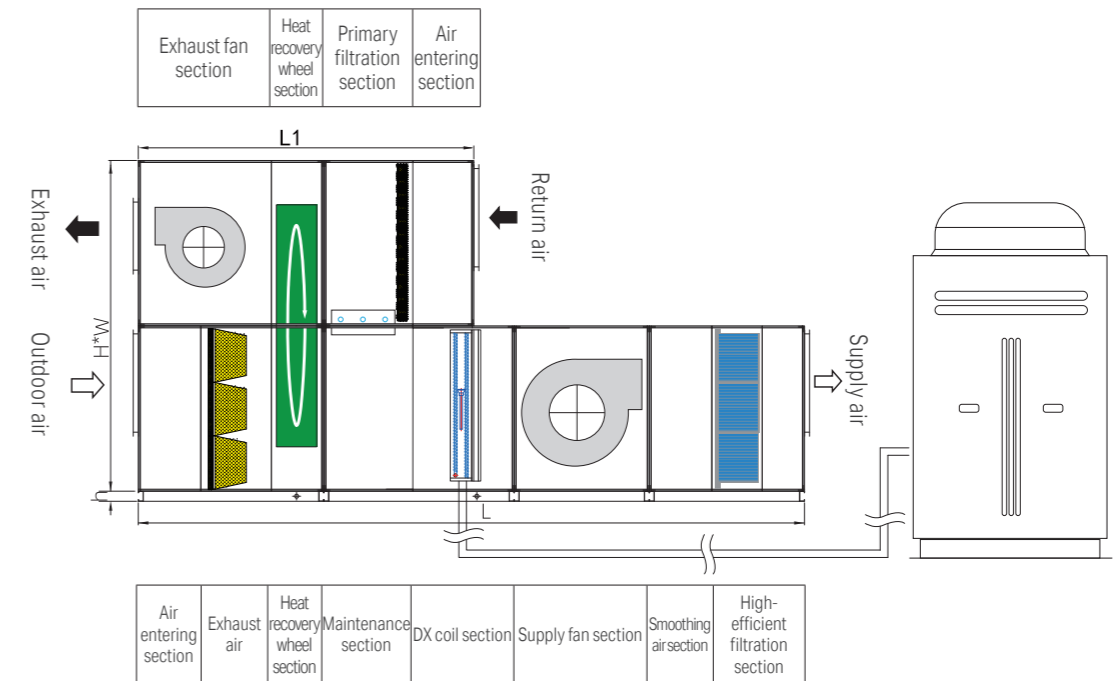

Indoor unit	Machine dimensions (mm)			Duct size (mm)		Weight (kg)
	L	L1	H * W	OA / RA	SA / EA	
HZN-10	5360	2780	1680×1240	1075×275	475×475	1537
HZN-12	5360	2780	1880×1240	1075×275	475×475	1590
HZN-15	5560	2880	1880×1340	1175×375	575×575	1715
HZN-18	5560	2880	2080×1340	1175×375	575×575	2050
HZN-20	5760	2980	2280×1740	1575×475	575×575	2238
HZN-24	5760	2980	2680×1740	1575×475	675×675	2536
HZN-30	5960	3080	2880×1840	1675×475	775×775	2986
HZN-36	6160	3180	2880×1840	1675×575	775×775	3410
HZN-40	6160	3180	3280×2240	2075×575	775×775	3813
HZN-48	6360	3280	3480×2240	2075×675	875×875	4041
HZN-60	6760	3480	3880×2440	2075×675	975×975	4447

Note: 1. The above dimensions are only for the unit size with 25mm panels, when equipped with 50mm panels, sizes are L+50mm, W+50mm, H+50mm.
2. H = 100mm.

SIDE DISCHARGE OUTDOOR UNIT

Model	A (mm)	B (mm)	C (mm)
HFM-05HA1、HFM-06HA1	903	393	1225
HFM-08HA1	903	393	1357

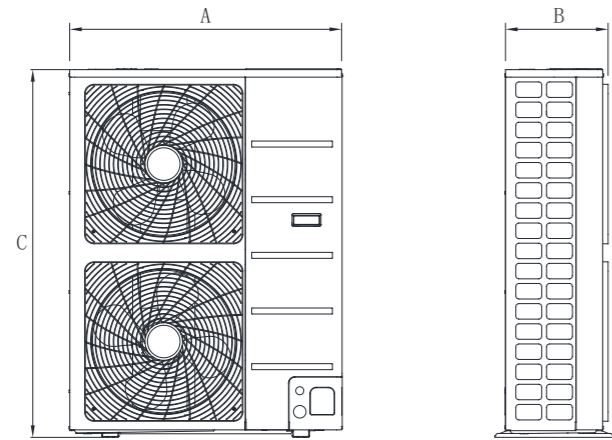

TOP DISCHARGE OUTDOOR UNIT

Standard model	A (mm)	B (mm)	C (mm)
HFM-10HA1、HFM-12HA1	990	850	1545
HFM-15HA1	990	850	1810
HFM-18HA1	1345	850	1810

DC inverter model	A (mm)	B (mm)	C (mm)
HFM-10HA1-DC	990	850	1810
HFM-12HA1-DC			
HFM-15HA1-DC			
HFM-18HA1-DC	1345	850	1810
HFM-20HA1-DC			

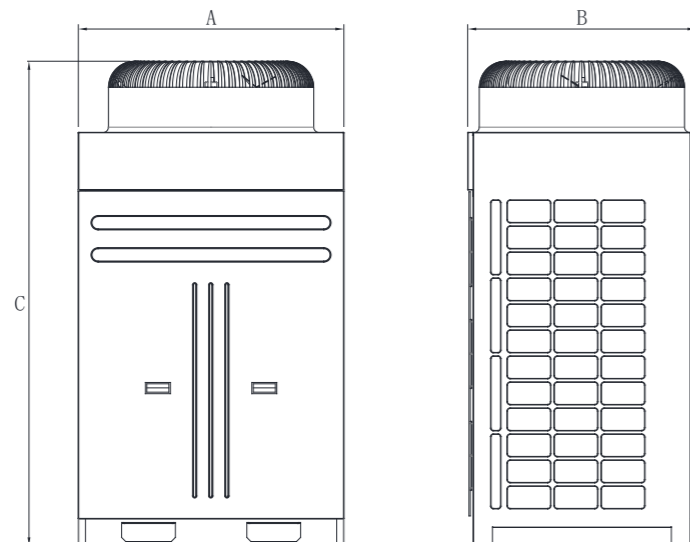

1. Table of correction coefficient of cooling capacity under different working conditions

Energy coefficient (ε1) Outdoor dry bulb temp. (°C)	Indoor wet bulb temp. (°C)							
	17	18	19	20	21	22	23	
25	1.07	1.10	1.14	1.15	1.17	1.23	1.32	
30	1.05	1.07	1.09	1.11	1.14	1.18	1.25	
35	0.98	0.99	1.00	1.03	1.06	1.09	1.13	
40	0.89	0.91	0.93	0.95	0.97	0.99	1.00	
43	0.86	0.88	0.90	0.92	0.94	0.96	0.97	

2. Table of correction coefficient of heating capacity under different working conditions

Energy coefficient (ε1) Outdoor dry bulb temp. (°C)	Indoor wet bulb temp. (°C)											
	14	12	10	8	6	4	2	0	-2	-4	-6	-8
10	1.23	1.18	1.12	1.07	1.01	0.95	0.89	0.83	0.78	0.74	0.70	0.67
15	1.23	1.17	1.11	1.05	1.00	0.94	0.89	0.83	0.78	0.73	0.69	0.66
20	1.20	1.15	1.10	1.05	1.00	0.94	0.89	0.83	0.77	0.72	0.68	0.65
25	1.15	1.13	1.10	1.05	0.99	0.93	0.88	0.83	0.77	0.72	0.67	0.63

3. Table of air volume impact on cooling capacity

Calculated airflow/Nominal airflow	0.6	0.7	0.8	0.9	1.0	1.2	1.4	1.6	2.0
Actual cooling capacity	0.87	0.91	0.95	0.98	1.00	1.04	1.08	1.12	1.2

4. Correction table of the influence of the connecting pipe length and installation height difference between indoor and outdoor units on cooling capacity.

Factors	Correction coefficient of cooling capacity														
	Total equivalent length of connecting pipes	5m	10m	15m	20m	25m	30m	35m	40m	45m	50m	55m	60m	65m	70m
Indoor units higher than outdoor units	0m	1.00	0.98	0.96	0.94	0.92	0.90	0.88	0.86	0.84	0.84	0.80	0.78	0.76	0.74
	5m	1.00	0.97	0.95	0.93	0.91	0.89	0.87	0.85	0.83	0.81	0.79	0.77	0.75	0.73
	10m	-	0.96	0.94	0.92	0.90	0.88	0.86	0.84	0.82	0.80	0.78	0.76	0.74	0.72
	15m	-	-	0.93	0.91	0.89	0.87	0.85	0.83	0.81	0.79	0.77	0.75	0.73	0.71
	20m	-	-	-	0.9	0.88	0.86	0.84	0.82	0.80	0.78	0.76	0.74	0.72	0.70
	25m	-	-	-	-	0.87	0.85	0.83	0.81	0.79	0.77	0.75	0.73	0.71	0.69
Indoor units lower than outdoor units	0m	1.00	0.98	0.96	0.94	0.92	0.90	0.88	0.86	0.84	0.82	0.8	0.78	0.76	0.74
	5m	1.00	0.98	0.96	0.94	0.92	0.90	0.88	0.86	0.84	0.82	0.8	0.78	0.76	0.74
	10m	-	0.98	0.96	0.94	0.92	0.90	0.88	0.86	0.84	0.82	0.8	0.78	0.76	0.74
	15m	-	-	0.96	0.94	0.92	0.90	0.88	0.86	0.84	0.82	0.8	0.78	0.76	0.74
	20m	-	-	-	0.94	0.92	0.90	0.88	0.86	0.84	0.82	0.8	0.78	0.76	0.74
	25m	-	-	-	-	0.92	0.90	0.88	0.86	0.84	0.82	0.8	0.78	0.76	0.74

Note: the equivalent total length of the connecting pipe is the sum of the total length of the straight pipe plus the equivalent length of the elbow and the oil storage bend. The equivalent length of elbow and oil storage bend is commonly shown in the following table:

Outer diameter of gas pipes	ø15.88	ø19.05	ø22.22	ø28.58	ø34.93	ø41.28
Elbow	0.25m	0.35m	0.45m	0.50m	0.55m	0.60m
Oil storage bend	2.0m	2.4m	2.9m	3.7m	4.1m	4.8m

SAFE OPERATING CONDITIONS OF AHU

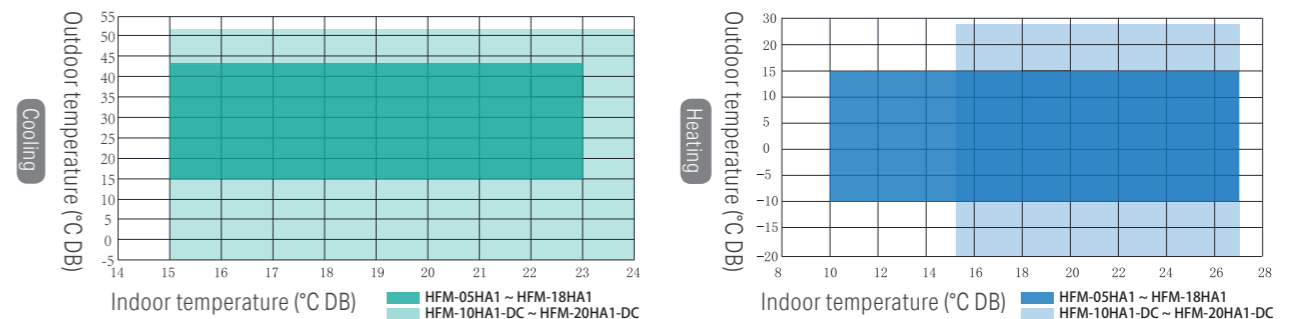

Note: The operating ranges of HFM-05HA1~HFM-18HA1 and HFM-10HA1-DC~HFM-20HA1-DC are shown above. If the air conditioning unit is used outside the scope of the above working conditions, the safety protection function will be activated and may lead to abnormal operation.



1 Dajiangdong wisdom valley project in Hangzhou city



2 National Convention Centre Phase II

3 National Bobsleigh and Tobogganing Sport Center



4 Nanchang Financial Square

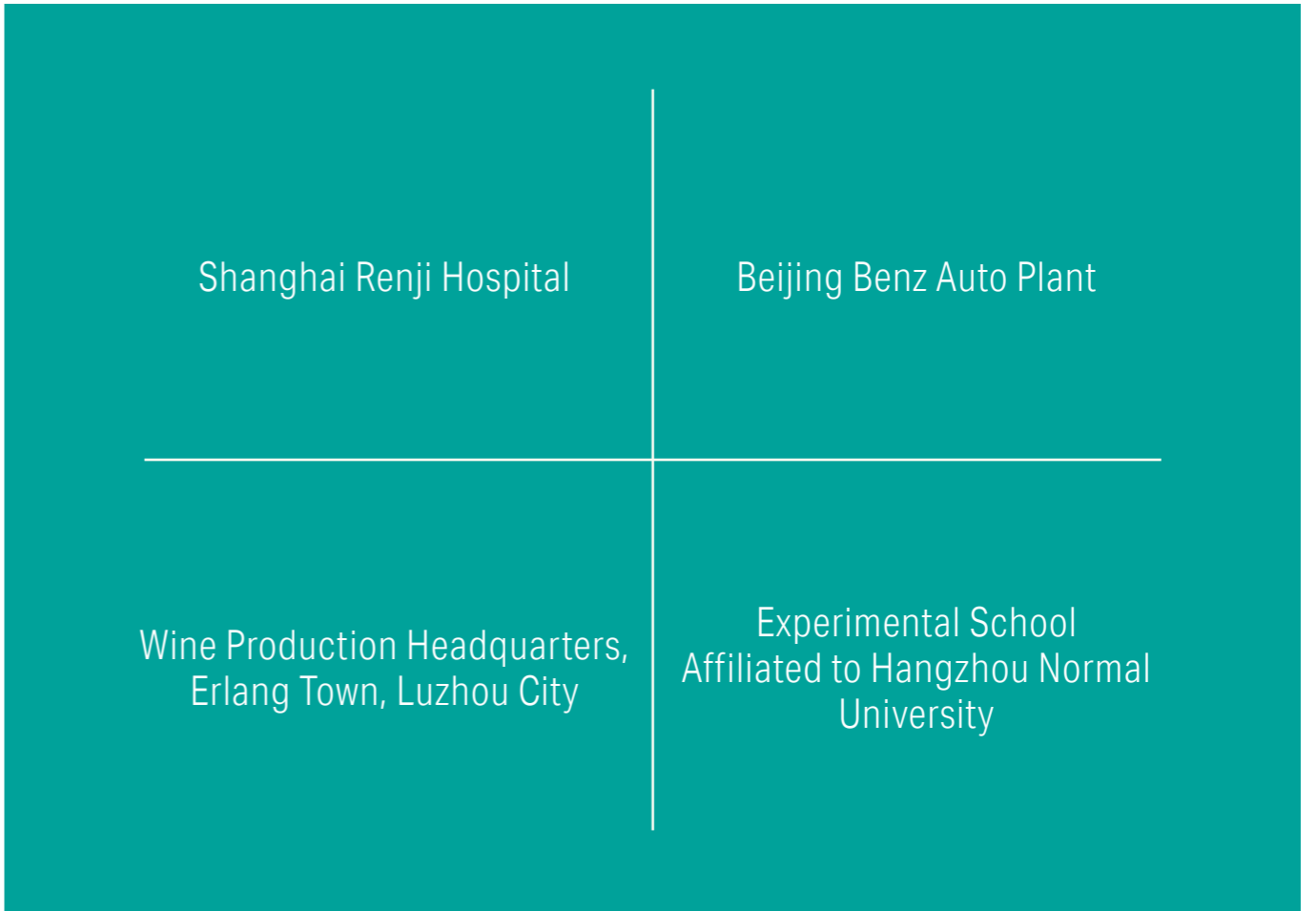

Shanghai Renji Hospital

Beijing Benz Auto Plant

Wine Production Headquarters, Erlang Town, Luzhou City

Experimental School Affiliated to Hangzhou Normal University

